



Thank you for purchasing our product. Before installing/operating the product, read the instructions carefully and retain them for future reference.

⚠ Attention!

- For installation, follow the steps described. Any damage caused by wrong installation shall be imputed to the users.
- To avoid a short circuit from occurring do not pull or modify the wires during installation.
- Do not disassemble or change any parts. Opening and disassembling this unit will void any warranty.
- Maintenance and repairs should be executed by our professionals only.

Symbol description:

NOTE

⚠ Some procedures must be followed to avoid damages to the product.

⚠ **WARNING!** Certain procedure must be followed to avoid damages to yourself, to the vehicle or to others.



Flash



Light on



Hold the Button
1 second



Hold the Button
3 seconds

1 Accessories



2-1 Installation description

Proceed as follows

- 1 LCD Meter (Accessories 1)
- 2 Bushing (Accessories 2)
- 3 M5 washer X3 (Accessories 3)
- 4 M5x20L Screw X1 (Accessories 4) $\times 0.58 \text{ Nm (5.8 kgf.cm)}$
- 5 M5x12L Screw X2 (Accessories 5) $\times 0.55 \text{ Nm (5.5 kgf.cm)}$

NOTE Refer to the icon to disassemble. And install according to the reverse order of disassembly.

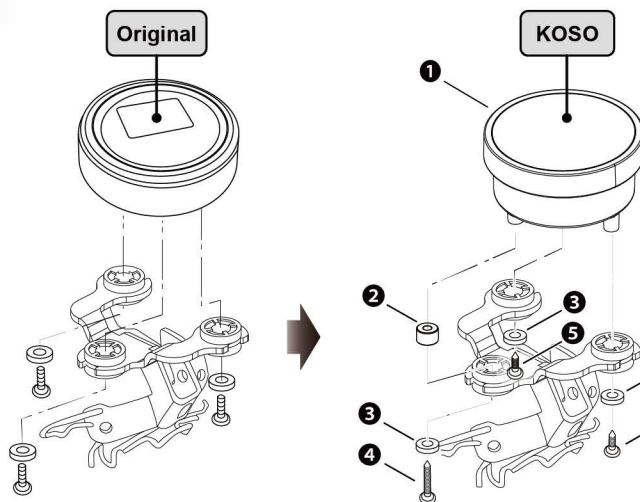
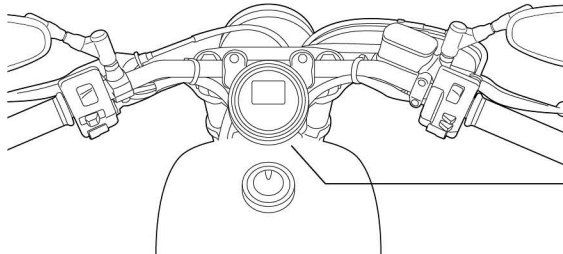

Proceed as follows

- 1 LCD Meter (Accessories 1)
- 2 Bushing (Accessories 2)
- 3 M5 washer X3 (Accessories 3)
- 4 M5x20L Screw X1 (Accessories 4) $\times 0.58 \text{ Nm (5.8 kgf.cm)}$
- 5 M5x12L Screw X2 (Accessories 5) $\times 0.55 \text{ Nm (5.5 kgf.cm)}$

NOTE Refer to the icon to disassemble. And install according to the reverse order of disassembly.

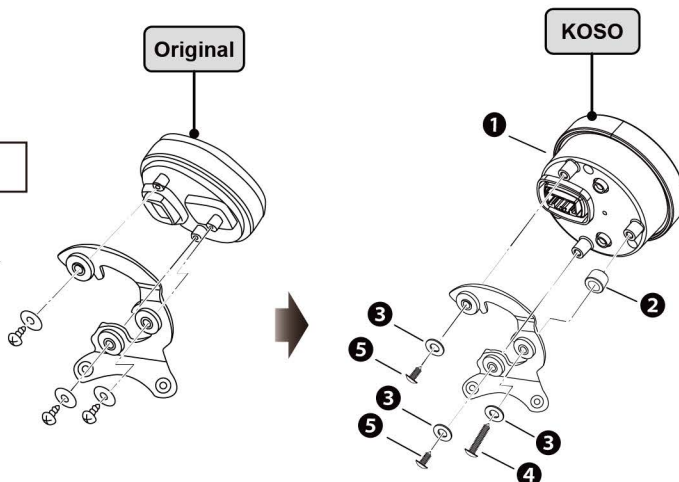
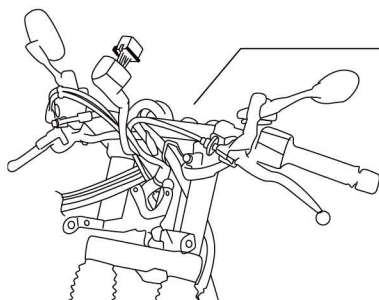

2-2 Wiring installation instructions

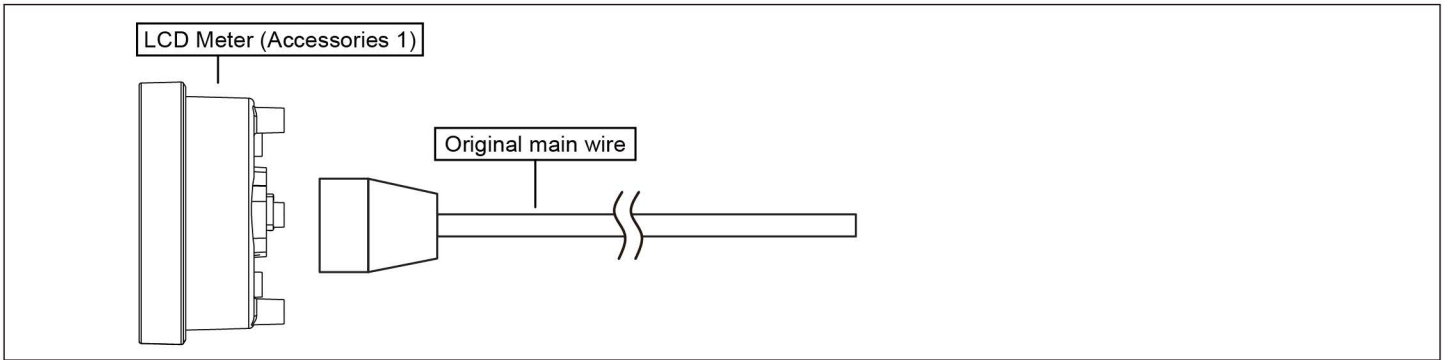

3-1 Meter Size

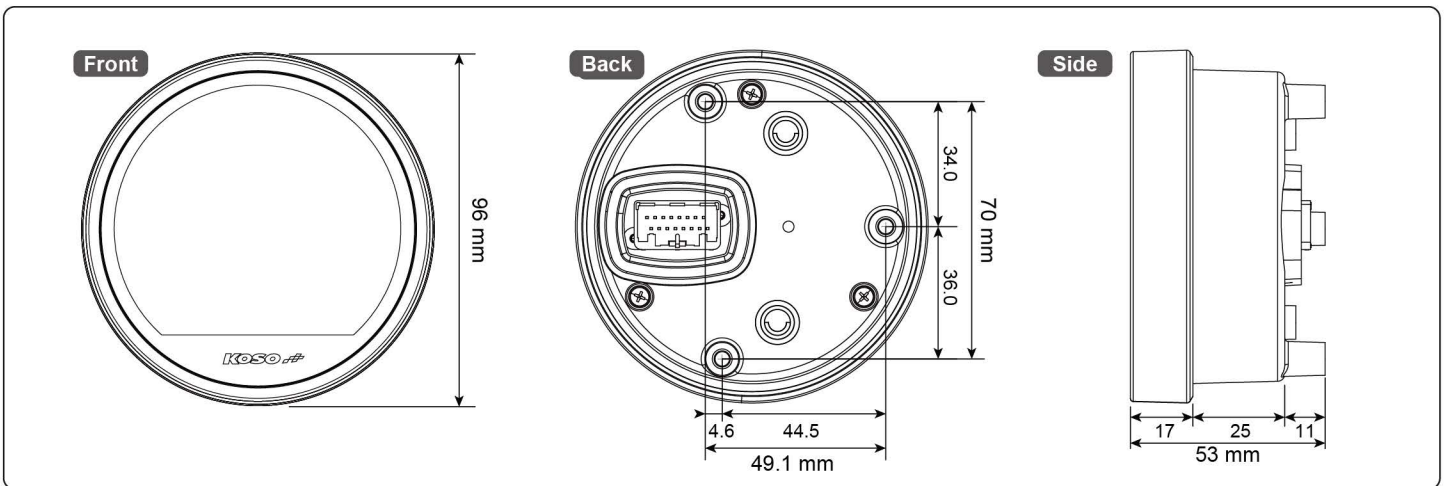

3-2 Button Function Description

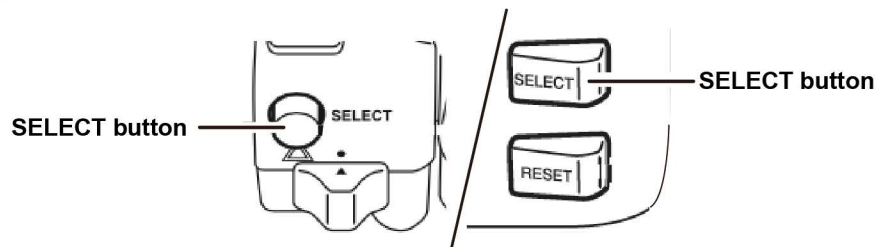

3-3 Basic Function Instructions

- Indicator**
- Check engine light (Amber)
 - High beam light (Blue)
 - Neutral light (Green)
 - Warning light (Red)
 - ABS light (Amber)
 - Turn signal light (Green)
 - Anti-theft light (Red)

- Speedometer**
- Display range : 0 ~ 360 km/h (0 ~ 225 MPH)
 - Display unit : 1 km/h (MPH)

- Max. speed record**
- Display range : 0 ~ 360 km/h (0 ~ 225 MPH)
 - Display unit : 1 km/h (MPH)

- Max. Gear record**
- Display range : -, N, 1~5 gear

- Max. RPMh**
- Display range : 0~10,000 RPM
 - Display unit : 100 RPM

- Max. temperature record**
- Display range : -30~225 °C (-22~437 °F)
 - Display unit : 1 °C (°F)

- Clock**
- Setting range : 00:00~23:59 (24H)
 - 01:00~12:59 (12H)

- Voltmeter**
- Display range : DC 8.0 ~ 18.0 V
 - Display unit : DC 0.1 V

- Temperature**
- Display range : --- /-30~225 °C (-22~437 °F)
 - Display unit : 1 °C (°F)



- Tachometer**
- Display range : 0~10,000 RPM
 - Display unit : 100 RPM







- Odometer**
- Display range : 0 ~ 999,999 km (mile)
 - Display unit : 1 km (mile)

- Trip meter A, B**
- Display range : 0.0~9,999.9 km (mile)
 - Display unit : 0.1 km (mile)

- Motor oil maintenance (Trip O)**
- Display range : OFF, -999~16,000 km (-999~10,000 mile)
 - Display unit : 1 km (mile)

- Gear Meter**
- Display range : -, N, 1~5 gear

3-4 Specifications

●Speedometer	Display range : 0 ~ 360 km/h (0 ~ 225 MPH) Display unit : 1 km/h (MPH) Switchable	●Temperature	Display range : --- /-30~225 °C (-22~437 °F) Display unit : 1 °C (°F)
○Speeding warning setting	Setting range : 30~360 km/h (19~225 MPH), When exceeding the set value (inclusive), the value flickers and the warning signal will be lit according to the setting. Setting unit : 1 km/h (MPH)	○Overheat warning setting	Setting range : 60~225 °C(140~437 °F), When exceeding the set warning value, the value flickers, and the warning signal will be lit according to the setting. Setting unit : 1 °C (°F)
○Max. speed record	Display range : 0 ~ 360 km/h (0 ~ 225 MPH), can return to zero manually Display unit : 1 km/h (MPH)	○Max. temperature record	Display range : -30~225 °C (-22~437 °F), can return to zero manually Display unit : 1 °C (°F)
○Odometer	Setting range : 0 ~ 99,999 km (mile) Setting unit : 1 km (mile)	●Fuel meter	Display range : ON, OFF, unusual warning
○Trip meter A, B	Display range : 0.0~9,999.9 km (mile), can return to zero manually Display unit : 0.1 km (mile)	●Clock	Setting range : 00:00~23:59 (24H) 01:00~12:59 (12H)
●Motor oil maintenance (Trip O)	Display range : OFF, -999~16,000 km (-999~10,000 mile), can be reset manually Display unit : 1 km (mile)	●Voltmeter	Display range : DC 8.0 ~ 18.0 V Display unit : DC 0.1 V
○Motor oil maintenance warning	Setting range : OFF, 500 ~ 16,000 km (300~10,000 mile) When lower than 0 km (mile), the value shows on the screen and flickers for warning, and the warning signal will be lit according to the setting. Setting unit : 100 km (mile)	○Low voltage warning	Setting range : DC 8.0~13.0 V, When lower than the set warning value for over five seconds, the value flickers, and the warning signal will be lit according to the setting. Setting unit : DC 0.1 V
●Trip F	Display range : 0.0~9,999.9 km (mile), can be reset manually Display unit : 0.1 km (mile)	●Backlight brightness	Setting range : 1/5 (darkest)~ 5/5 (brightest) Setting unit : 1/5 (20%)
●Tire percentage	Setting range : 50~200 % Setting unit : 1 %	●Unit	Speed unit : km/h , MPH Temperature unit : °C (Celsius) and °F (Fahrenheit)
●Gear Meter	Display range : -, N, 1~5 gear	○Operating voltage	DC 12V
○Max. Gear record	Display range : -, N, 1~5 gear, can return to zero manually	●Operating temperature	-10~+60 °C
●Tachometer	Display range : 0~10,000 RPM Display unit : 1,000 RPM (Large grid) / 111 RPM (Small grid)	○Storage temperature	-20~+80 °C
○Shift light warning	Setting range : 1,000~10,000 RPM, When exceeding the set value (inclusive), the warning signal will be lit according to the setting. Setting unit : 100 RPM	●Specification	JIS D 0203 (S2)
○Max. RPM record	Display range : 0~10,000 RPM, can return to zero manually Display unit : 100 RPM	●Meter Size	D 96 mm
		●Meter Weight	± 184 g
		●Indicator	Check engine light (Amber)  High beam light (Blue)  Neutral light (Green)  Warning light (Red)  ABS light (Amber)  Turn signal light (Green)  Anti-theft light (Red) 

NOTE Design and specifications are subject to change without notice.

4 Main Menu Switching Description(including the warning screen)

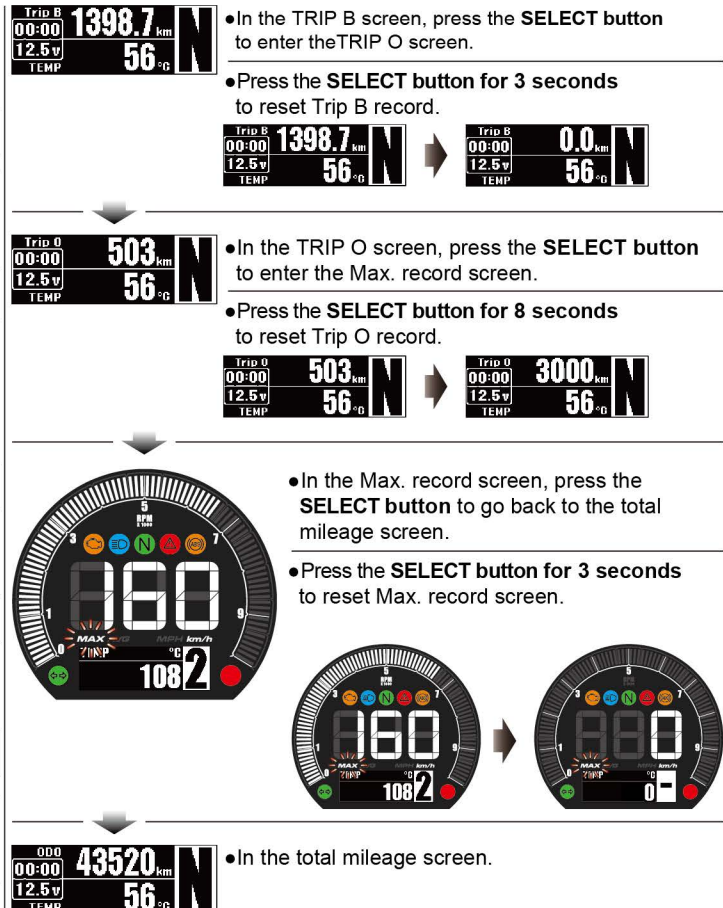
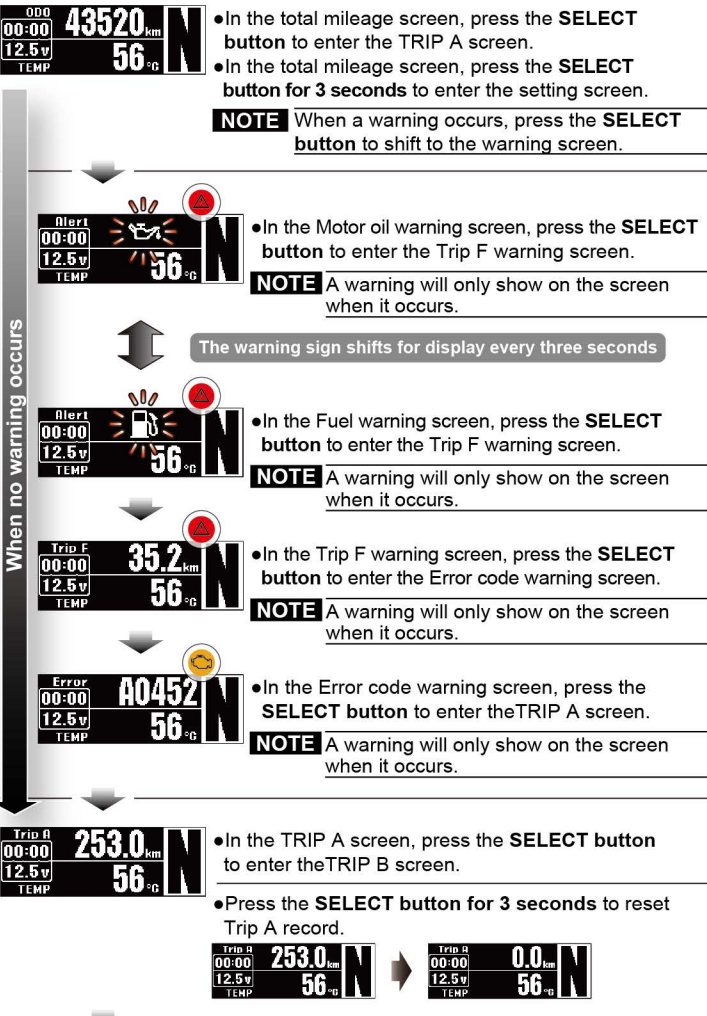

5 Setting Screen Switching Description

● Press the **SELECT** button for 3 seconds on the main screen(ODO) to switch to the setting screen.

● Press the **SELECT** button to select

① Clock ② Unit(Speed/Temperature) ③ Backlight(Brightness) ④ Tire Percentage ⑤ Gear ⑥ Speeding warning ⑦ Shift light warning ⑧ Overheat warning ⑨ Voltage warning ⑩ Motor oil maintenance(Trip O) ⑪ Warning light warning ⑫ ABS warning ⑬ Internal and External ODO ⑭ Exit.

NOTE During setting, if any button is not pressed for 30 seconds, it will automatically return to the startup screen.



5-1 Clock Setting



● The Clock screen, press the **SELECT** button for 3 seconds to enter the Clock setting.



● Press the **SELECT** button for 3 seconds to move to the digit you want to set.

● EX: To set clock(minute) as 10 minutes.

⚠ Now the setting value is flashing.

NOTE Setting range : 00~59 minutes.
Default value : 0.



● Example : Changing to 12H.

● Press the **SELECT** button to choose the setting option.

⚠ Now the setting value is flashing.

NOTE Setting range : 12 H, 24 H.
Default value : 24 H.



● Press the **SELECT** button to choose the setting number.



● EX : Set time format from 24 H to 12 H.

● Press the **SELECT** button for 3 seconds to enter time adjustment hour setting.



● EX : Set minute from 0 minutes to 10 minutes.

● Press the **SELECT** button for 3 seconds to go back to the Clock screen.



● Example : To set clock(hour) to 10 hours.

● Press the **SELECT** button to choose the setting number.

⚠ Now the setting value is flashing.

NOTE Cursor moving order is :
Hour → Digit in ten minutes →
Digit in minutes

NOTE Setting range : 1~12(12H)
0 ~23(24H)
Default value : 12(12H)/0(24H)

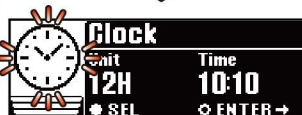

● The Clock screen.



● EX : Set hour from 12:00 AM to 10:00 AM.

● Press the **SELECT** button for 3 seconds to enter clock adjustment minute setting.

5-2 Unit (Speed, Temperature) Setting



- The unit screen, press the **SELECT** button for 3 seconds to enter the speed unit setting.



- **Example** : To set speed unit in MPH.
- Press the **SELECT** button to choose the setting options.

⚠ Now the setting value is flashing.

NOTE Setting range : km/h, MPH.
Default value : km/h .



- **EX** : Set speed unit from km/h to MPH.
- Press the **SELECT** button for 3 seconds to enter the temp. unit setting screen.

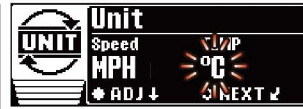

- **Example** : To set temp. unit to °F (Fahrenheit).
- Press the **SELECT** button to choose the setting options.

⚠ Now the setting value is flashing.

NOTE Setting range : °C (Celsius) and °F (Fahrenheit).
Default value : °C (Celsius).

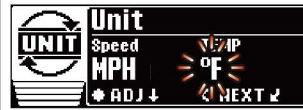

- **EX** : Set temp. unit from °C (Celsius) to °F (Fahrenheit).
- Press the **SELECT** button for 3 seconds to go back to the unit screen.



- The unit screen.

5-3 Backlight(Brightness) Setting



- The backlight screen, press the **SELECT** button for 3 seconds to enter the backlight setting.



- **Example** : To set the backlight brightness to 2/5(40%).
- Press the **SELECT** button to choose the setting number.

⚠ Now the setting value is flashing.

NOTE Setting range : 1/5 (Darkest)~ 5/5 (Brightest).
Setting unit : 20% per level.
Default value : 3/5(60%).

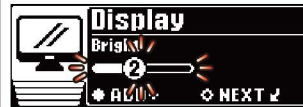

NOTE The backlight brightness will change immediately after you set the value.

- **EX** : The backlight brightness setting is changed from 3/5 (60%) to 2/5 (40%).
- Press the **SELECT** button for 3 seconds to go back to the backlight screen.



- The backlight screen

5-4 Tire Percentage Setting



- The tire percentage screen, press the **SELECT** button for 3 seconds to enter the tire percentage setting.



- Reset this setting value when you change a different size tire.
- **Example** : The new tire circumference is 1,527 mm. The calculation equation is as below.
- The new tire circumference 1,527mm ÷ the original tire circumference 1,454 mm X (100 %) =The setting value (105 %).
- Press the **SELECT** button for 3 seconds to move to the digit you want to set.

⚠ Now the setting value is flashing.

NOTE Cursor's order : operation setting, hundred → ten → digit

NOTE Setting range : 50 %~200 %.
Default value : 100 %.

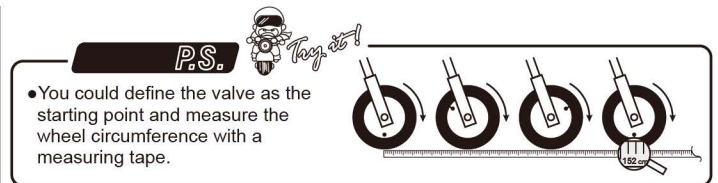

- P.S.** *Try it!*
- You could define the valve as the starting point and measure the wheel circumference with a measuring tape.



- Press the **SELECT** button to choose the setting number.



- **EX** : The tire percentage setting is changed from 100 % to 105 %.
- Press the **SELECT** button for 3 seconds to go back to the tire percentage setting.



- The tire percentage screen.



When changing gears or tire size, it can adjust the tire percentage (%) parameter to calibrate speed.

1. When switching tire size

$$\text{Tire percentage (\%)} = \frac{1,527}{1,454} \times 100 = 105\%$$



Tire size from small to large

Standard



Tire size from large to small

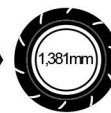

$$\text{Tire percentage (\%)} = \frac{1,381}{1,454} \times 100 = 95\%$$

5-5 Gear Setting

ON,OFF



- The gear screen, press the **SELECT** button for 3 seconds to enter the gear setting.



- Example : You want to set the gear setting to ON.
- Press the **SELECT** button to choose the setting options.
- ⚠ Now the setting value is flashing.
- NOTE** Setting range : ON, OFF, Reset.
Default value : ON.
- NOTE** Select OFF to return to the gear screen.



- EX : Set the gear setting to ON.
- Press the **SELECT** button for 3 seconds to enter the gear-learning setting screen.



- Press the **SELECT** button to start the gear-learning setting.
- NOTE** Enter the Learning Mode, and learn the Gear position according to the speed and RPM.



- In the gear-learning setting.
- ⚠ **CAUTION!**
Before setting, be sure to put your motor in Neutral to avoid error detection.
- ⚠ **CAUTION!**
"Fail" on the screen means error detection, re-set Gear-Learn.
- ⚠ **CAUTION!**
If gear learning is not required, press **SELECT** button to cancel the gear learning.

PS. *Try it!*

- During actual gear level learning, select road that is wide and has more straight distance with no traffic lights for more accurate settings and traffic safety.

- When N→1 appears, change to Gear 1 to ride. When Gear 1 is detected, 1→2 appears and then change to Gear 2.



- 1 → 2 ○ Change to Gear 2.
- 2 → 3 ○ Change to Gear 3.
- 3 → 4 ○ Change to Gear 4.
- 4 → 5 ○ Change to Gear 5.

- NOTE** Press the **SELECT** button to quit the learning and return to the main screen.



- After reaching and finishing Gear 5, when 5→6 is displayed, wait for a few seconds to end gear-learning and return to the gear screen.



- The gear screen.

Reset



- The gear screen, press the **SELECT** button for 3 seconds to enter the gear setting.



- Example : You want to set the gear setting to Reset.
- Press the **SELECT** button to choose the setting options.
- ⚠ Now the setting value is flashing.
- NOTE** Setting range : ON, OFF, Reset.
Default value : ON.
- NOTE** Select OFF to return to the gear screen.



- EX : Set the gear setting to Reset.
- Press the **SELECT** button for 3 seconds to enter the Reset setting screen.



- Press the **SELECT** button, and select whether to Reset the setting.
- Press the **SELECT** button for 3 seconds to confirm the option and return to the gear screen.

⚠ Now the setting value is flashing.

- NOTE** Setting range : NO, YES.



- The gear screen.

5-6 Speed warning Setting



- The Speed warning screen, press the **SELECT** button for 3 seconds to enter the speed warning setting.



- EX : Set speed warning value from 90 km/h to 95 km/h.
- Press the **SELECT** button for 3 seconds to go back to the speed warning screen.



- **Example** : To set speed warning value to 95 km/h.
- Press the **SELECT** button for 3 seconds to move to the digit you want to set.

⚠ Now the setting value is flashing.

NOTE Setting range : 30~360 km/h
(19~225 MPH).
Default value : 90 km/h (56 MPH).



- The Speed warning screen.



- Press the **SELECT** button to choose the setting number.

5-7 Shift light warning Setting



- The shift light warning screen, press the **SELECT** button for 3 seconds to enter the shift light warning setting.



- EX : Set shift light warning value from 6,000 RPM to 10,000 RPM.
- Press the **SELECT** button for 3 seconds to go back to the shift light warning screen.



- **Example** : To set shift light warning value to 10,000 RPM.
- Press the **SELECT** button for 3 seconds to move to the digit you want to set.

⚠ Now the setting value is flashing.

NOTE Setting range :
1,000 ~ 10,000 RPM.
Default value : 6,000 RPM.



- The shift light warning screen.



- Press the **SELECT** button to choose the setting number.

5-8 Overheat Warning Setting



- The overheat warning screen, press the **SELECT** button for 3 seconds to enter the overheat warning setting.



- EX : Set overheat warning value from 150 °C to 120 °C.
- Press the **SELECT** button for 3 seconds to go back to the overheat warning setting.



- **Example** : To set overheat warning value to 120 °C.
- Press the **SELECT** button for 3 seconds to move to the digit you want to set.

⚠ Now the setting value is flashing.

NOTE Setting range : 60 ~ 225 °C
(140 ~ 437 °F).
Default value : 150 °C (302 °F).



- The overheat warning screen.



- Press the **SELECT** button to choose the setting number.

5-9 Voltage warning Setting



- The voltage warning screen, press the **SELECT** button for 3 seconds to enter the low voltage warning setting.



- EX : Set low voltage warning value from DC 11.5 V to DC 11.0 V.
- Press the **SELECT** button for 3 seconds to go back to the voltage warning screen.



- Example : To set low voltage warning value to DC 11.0 V.
- Press the **SELECT** button for 3 seconds to move to the digit you want to set.

⚠ Now the setting value is flashing.

NOTE Setting range : DC 8.0~13.0 V.
Default value : DC 11.5 V.



- The voltage warning screen.



- Press the **SELECT** button to choose the setting number.

5-10 Maintenance mileage Setting



- The maintenance mileage screen, press the **SELECT** button for 3 seconds to enter the motor oil maintenance setting.



- Press the **SELECT** button to choose the setting number.



- Example : To set mileage maintenance to (ON).
- Press the **SELECT** button to choose the setting number.

⚠ Now the setting value will blink.

NOTE Settings range : ON, OFF.
Default value : ON.



- EX : Set the mileage maintenance from 3,000 km to 12,000 km.
- Press the **SELECT** button for 3 seconds to return to mileage maintenance main screen.



- EX : Set mileage maintenance to (ON).
- Press the **SELECT** button for 3 seconds to enter into the mileage maintenance main screen.

NOTE When set to OFF, will directly return to mileage maintenance main screen.



- The maintenance mileage screen.



- Example : To set motor oil maintenance to 12,000 km.
- Press the **SELECT** button for 3 seconds to move to the digit you want to set.

⚠ Now the setting value is flashing.

NOTE Setting range : 500 ~ 16,000 km
(300~10,000 mile).
Default value : 3,000 km(1,700 mile).

5-11 Warning Light Setting



- The warning light screen, press the **SELECT** button for 3 seconds to enter the warning light setting.



- Press the **SELECT** button to choose the setting number.
- Press the **SELECT** button for 3 seconds to confirm selection.

⚠ Now the setting value is flashing.

NOTE Setting range : RPM, TEMP, Low Volt, Trip O, T-Gear, Speed.



- Press the **SELECT** button to choose the setting number.
- Press the **SELECT** button for 3 seconds to go back to the warning light screen.

⚠ Now the setting value is flashing.

NOTE Setting range : Steady, Flash, S-Flash, OFF.
Default value :
1. RPM : S-Flash
2. TEMP : S-Flash
3. Low Volt : S-Flash
4. Trip O : S-Flash
5. T-Gear : S-Flash
6. Speed : S-Flash



- The warning light screen.

5-12 ABS Warning Setting



- The ABS warning screen, press the **SELECT** button for 3 seconds to enter the ABS warning setting.



- Example : To set ABS warning value to ON .
- Press the **Select** button to choose the setting number.

⚠ Now the setting value will blink.

NOTE Settings range : ON, OFF.
Default value : ON.

⚠ When choosing ON, the ABS signal light (ABS) will activate.

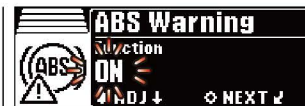

- EX : Set ABS warning to ON.
- Press the **SELECT** button for 3 seconds to return to ABS warning setting main screen.



- The ABS warning screen.

5-13 Internal and External ODO Setting

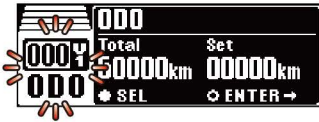

- The internal and external ODO screen, press the **SELECT** button for **3 seconds** to enter the external ODO setting.

⚠ User unable to adjust or clear internal ODO.

NOTE Display range :0 ~ 99,999 km (mile).



- EX : Set external total distance value from 00,000 km to 12,500 km.
- Press the **SELECT** button for **3 seconds** to go back to the internal and external ODO screen.



- Example : To set external total distance value to 12,500 km.
- Press the **SELECT** button for 3 seconds to move to the digit you want to set.

⚠ Now the setting value is flashing.

NOTE Cursor's order : one hundred thousand→ten thousands→thousand→hundred→ten→digit.

NOTE Setting range : 0~99,999 km (mile).



- The internal and external ODO screen.



- Press the **SELECT** button to choose the setting number.

5-14 Exit Setting



- The Exit screen, press the **SELECT** button for **3 seconds** to go back to the ODO main screen.



The ODO main screen.

6 Trouble Shooting

The following situations do not indicate malfunctions of the product. Check the following before taking it in for repair.

Trouble	Check item	Trouble	Check item
The meter doesn't work when the power is on.	<ul style="list-style-type: none"> •The power isn't supplied to the meter. →Make sure the wiring is connected. The wiring and fuse are not broken. →The battery is too old to supply needed power (DC 12 V). 	Thermometer doesn't appear or appears incorrectly.	<ul style="list-style-type: none"> •May be due to poor connection of wiring. →Check whether the wires are disconnected or have fallen off.
The meter doesn't appear or appear incorrectly.	<ul style="list-style-type: none"> •Check the voltage of your battery, and make sure the voltage is over DC 12 V. •Ensure the wiring is connected correctly. For any error code shown, refer to the manual from the original manufacturer. •May be due to poor connection of wiring. →Check whether the wires are disconnected or have fallen off. 	The clock is incorrect.	<ul style="list-style-type: none"> •Check the setting. →Check the settings menu, the clock settings are correct.
Speed doesn't appear or appears incorrectly.	<ul style="list-style-type: none"> •May be due to poor connection of wiring. →Check whether the wires are disconnected or have fallen off. 	Voltage doesn't appear or appears incorrectly.	<ul style="list-style-type: none"> •May be due to poor connection of wiring. →Check whether the wires are disconnected or have fallen off.
Tachometer doesn't appear or appears incorrectly.	<ul style="list-style-type: none"> •May be due to poor connection of wiring. →Check whether the wires are disconnected or have fallen off. 	The meter indicator didn't display.	<ul style="list-style-type: none"> •May be due to poor connection of wiring. →Check whether the wires are disconnected or have fallen off.

※If the problems still can't be solved, contact our technical department for assistance.