

SLA^{MAX}

FACTORY ACTIVATED

SLA MAX | PREMIUM QUALITY READY TO START

REF **51913**



12V VOLTAGE - V

275A CCA - A (EN)

22Ah CAPACITY - Ah (20Hr)

21Ah CAPACITY - Ah (10Hr)

TECHNOLOGY

- AGM construction (Absorbed Glass Material)
- VRLA battery (Valve Regulated Lead Acid)
- Activated and pre-charged batteries
- Homologated by OEM

FEATURES

- Factory activated : Ready-to-start battery
- Totally sealed
- Safe & Environmentally friendly
- Superior capacity
- Increased power & Extended life
- Low discharge rate
- Absolutely maintenance free
- Sealed, no gas emission through venting hole (under normal operation)
- Extreme vibration resistance
- Spillproof design
- Multi-positional fitment
- No acid handling - Very safe

UPGRADE FOR

DRY 51814 ; 51913
SLA SLA12-19

WEIGHT

Battery (with acid): approx 6.04kg

MOUNTING ANGLE

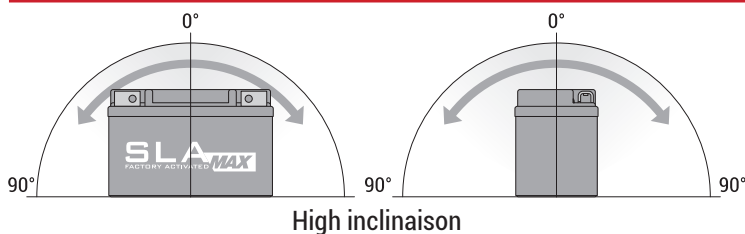

DIMENSIONS

Length (A): 183mm ±2mm
Width (B): 79mm ±2mm
Container height: 171mm ±2mm
Total height (C): 171mm ±2mm

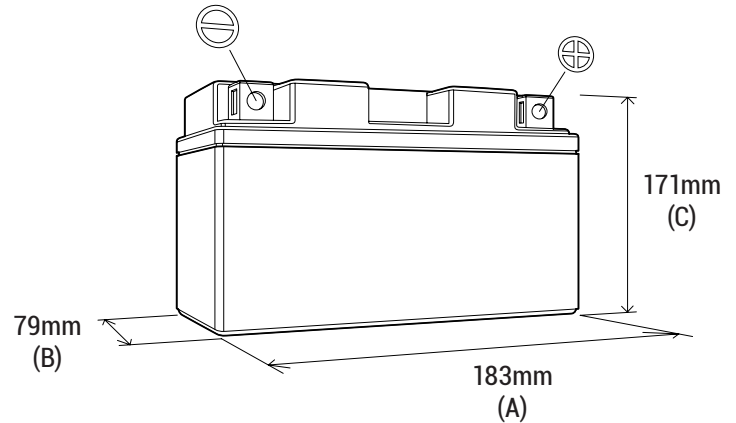

TERMINALS (mm)

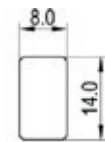

FRONT

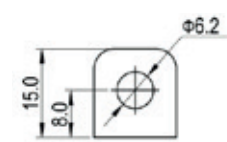

SIDE



TOP