



SLA

FACTORY ACTIVATED

SLA | READY TO START

REF **SLA12-19**



12V VOLTAGE - V

235A CCA - A (EN)

19Ah CAPACITY - Ah (20Hr)

17.7Ah CAPACITY - Ah (10Hr)

TECHNOLOGY

- Designed according to AGM technology (Absorbed acid)
- VRLA battery type
- Activated and pre-charged batteries
- Homologated by OEM

FEATURES

- AGM construction (Absorbed Glass Material)
- VRLA battery (Valve Regulated Lead Acid)
- Factory activated
- Environmentally friendly, spillproof design
- Multi-positional fitment
- Absolutely Maintenance free
- Sealed, no gas emission through venting hole (under normal operation)
- Ready & Easy to use
- No acid handling - Very safe
- Increased power & Extended life
- Extreme vibration resistance

UPGRADE FOR

DRY 51814 ; 51913

WEIGHT

Battery (with acid): **Approx 5.81kg**

MOUNTING ANGLE

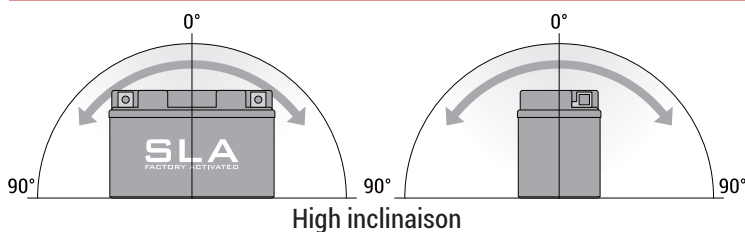

DIMENSIONS

Length (A): 182mm ±2mm
 Width (B): 77mm ±2mm
 Container height: 168mm ±2mm
 Total height (C): 168mm ±2mm

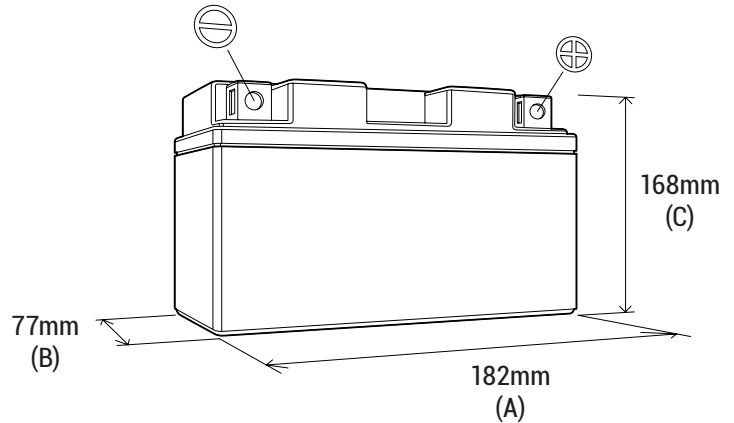

TERMINALS (mm)

