

# STAGE 6<sup>®</sup>

## R/T HIGH-END CYLINDER

Stage6 R/T 70cc – Minarelli LC  
Part number: S6-7516602



Instructions in other languages available at  
<http://www.stage6.de/instructions/S6-7516602>



## Content

- 1 Introduction \_\_\_\_\_
- 2 Installation instructions \_\_\_\_\_
  - 2.1 Preparation \_\_\_\_\_
- 3 Exhaust system \_\_\_\_\_
  - 3.1 Cylinder flange \_\_\_\_\_
- 4 Cylinder installation \_\_\_\_\_
  - 4.1 Cylinder base gaskets & squish clearance \_\_\_\_\_
  - 4.2 Cylinder adaptor plate \_\_\_\_\_
  - 4.3 Piston \_\_\_\_\_
  - 4.4 Cylinder \_\_\_\_\_
  - 4.5 Inner cylinder head cap & cylinder head cover \_\_\_\_\_
  - 4.6 Water connection \_\_\_\_\_
- 5 Ignition timing \_\_\_\_\_
- 6 Dimensional stability \_\_\_\_\_
- 7 Component overview \_\_\_\_\_
- 8 Replacement parts \_\_\_\_\_

## Technical Data

Engine	MINARELLI LC
Capacity	69,75 cc
Bore	47,60 mm
Stroke	39,2 mm
Conrod length	85 mm
Cooling system	Liquid-cooled
Compression	1:15,3
Max. power	26 hp
Max. torque	12 Nm

## Changes and documentation available at:

<http://www.stage6.de/instructions/S6-7516602>

## 1. Introduction

Firstly, we'd like to say *thank you* for buying this cylinder and thus showing your trust in our product and us. After months of development and testing – which didn't only involve the Stage6 R&D department, but also many other successful tuners and racing teams – we are very proud and happy that we can now present one of the highest developed 70 cc cylinders in the scootermatic racing sector.

### The patented modular system used offers several advantages:

- Short cylinder studs make for an optimal scavenging passage layout that increases cylinder charge.
- No obstruction of the exhaust port as is the case with the lateral studs of conventional cylinders.
- Using the fitting adaptor plate, the cylinder can be installed to all common engines.
- Very fast installation and removal.
- Very sturdy, CNC-milled cylinder head made of duraluminium with 5 attachment points.
- Optimised cooling system with cooling pockets around all 5 cylinder head screws.
- Viton® O-ring seal at the cylinder base.

## 2. Installation Instructions

### 2.1 Preparation

In order to be able to install the cylinder properly and to avoid potential problems right from the beginning, it is necessary to fulfil the listed requirements. Failure to do so may result in serious faults or malfunctions of cylinder, engine case and/or vehicle!

**Crankshaft:** Due to its construction, the cylinder can only be used in conjunction with a racing crankshaft with 85 mm conrod (*Part-no.: S6-7916685/12 Stage6 R/T Minarelli, Art.-Nr.: S6-7916688/12 Stage6 R/T Replica Minarelli*).

**Sealing surfaces:** The sealing surfaces of the engine case have to be in perfect condition. To ensure trouble-free operation, damaged or uneven surfaces must be avoided as this might damage certain parts, especially the cylinder. If the engine case is damaged, it will have to be replaced or reconditioned by a qualified mechanic.

**Spigot mouth diameter:** The diameter of the cylinder base is 55.70 mm. In order to be able to install the cylinder, it is necessary to strip the crankcase and revise it in the area around the cylinder base. The crankcase of Minarelli models will have to be milled to a diameter of 56.70 mm with a depth of 10 mm.

**Fuel & oil addition:** Due to the higher compression and in order to achieve the highest power possible, a fuel with

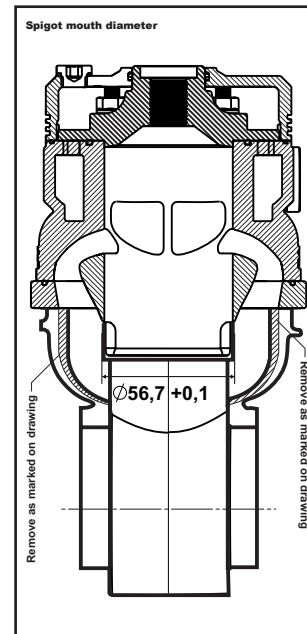

an octane rating of 100 or more should be used. Low-quality and low-octane fuels can result in damage to the cylinder. Furthermore, only fully synthetic two-stroke engine oils should be used. The recommended ratio of 1:33 should be observed; a lower ratio should not be used.

### 3. Exhaust System

#### 3.1 Cylinder Flange

Due to the changed attachment points for the exhaust flange, a flange that fits the exhaust system has to be used. The different flange types available are listed under *8. Replacement Parts*. We recommend using the R/T exhaust system (*Part no.: S6-9616605*).

### 4. Cylinder Installation

#### 4.1 Cylinder Base Gaskets & Squish Clearance

Before installing the cylinder base gaskets, check the sealing surfaces for damage. If the engine case is damaged, it will have to be replaced or reconditioned by a qualified mechanic. The surfaces must be clean and free of residues. Make sure that the squish clearance measures around 0.40 mm (+0.10/-0.05 mm) at the narrowest point. This value can be changed using different cylinder base gaskets. It is possible to use two gaskets as maximum, but ideally no more than one should be used. Squish clearance must be measured at two opposite points.

#### 4.2 Cylinder Adaptor Plate

Fix the adaptor plate using the four black M7 x 27 mm hexagon socket

screws, which must be tightened evenly in a criss-cross sequence to a torque of 13 Nm. If these screws have been damaged during an engine overhaul, they must be replaced by *part no. S6-75166ET34!* Between cylinder adaptor plate, gasket(s) and engine case, a thin film of permanently elastic sealing compound must be used. Screw the M7/M8 studs into the adaptor plate, tightening them finger-tight. **Note that the M7/M8 x 30 mm studs are screwed facing towards the exhaust and the M7/M8 x 32 mm studs are screwed into the upper mounting points.** The cylinder is sealed via a Viton® seal, which is placed into the groove of the adaptor plate. Take care that the seal isn't displaced and squashed when positioning the cylinder.



#### 4.3 Piston

Install the piston with the arrow on the top facing towards the exhaust. Before installing the piston for the first time, you should check the piston as well as the ports in the cylinder liner for burrs and sharp edges. Affected areas must be sanded using fine-grade sandpaper. Position the piston ring into the ring groove so that the locating pin is in between the ends of the ring. Also make sure that the gudgeon pin circlips are properly seated.

#### 4.4 Cylinder

Before installation check the cylinder for production residues (e.g. metal dust and shavings) and clean it if necessary. Then moisten the cylinder liner with two-stroke oil and carefully slide the cylinder over the piston until the piston touches the sealing surface of the adaptor plate. When positioning the cylinder, it is essential to ensure that the seal is properly placed inside the respective groove. This will have to be verified every time you install the cylinder; otherwise, serious malfunctions may occur.

#### 4.5 Inner Cylinder Head Cap & Cylinder Head Cover

After the cylinder has been installed and the squish clearance has been established (*see 4.1 Cylinder Base Gaskets & Squish Clearance*), the inner cylinder head cap must be mounted. Screw the supplied five M6 studs into the top of the cylinder. Make sure that they are positioned correctly (*see illustration 1*). Then place the Viton® seal (d = 60 mm) into the cylinder's inner groove, ensuring it is properly seated. Fix the inner cap by tightening the M6 cap nuts evenly in a criss-cross sequence to a torque of 11 Nm. Then place the wider Viton® seal into the outer groove, fixing it with grease or sealant if necessary. Insert the seal for the spark plug hole into the inside of the cylinder head cover, ensuring it is properly seated. The head cover must be mounted with the water connection opposite the exhaust port and fixed using the four M6 30 mm hexagon socket screws. The supplied copper washer must be placed under the vent plug, which is marked by the inscription *Air* on the head cover.

#### 4.6 Water Connection

For Piaggio engines, this connection will not be needed. Close off the lateral water connection with the screw plug and a seal beneath, tightening the plug to a torque of 8 Nm.

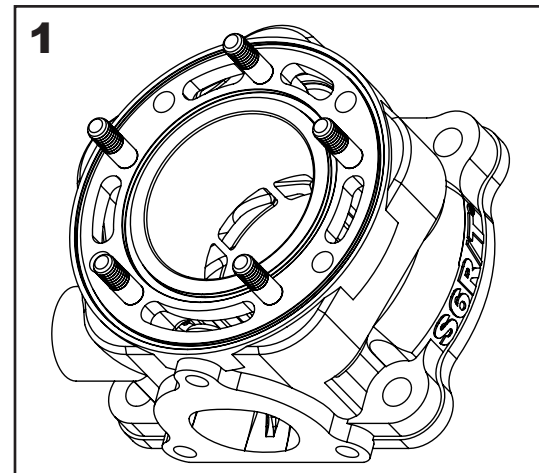

## 5. Ignition Timing

Pay especial attention to the ignition timing as incorrect timing may lead to power loss or damage to the engine! We recommend using the Stage6 R/T inner rotor ignition (*Part no.: S6-4516600*). It has been developed specifically for this cylinder and helps to achieve maximum power.

The adjustments necessary can be found in the instructions of the Stage6 R/T inner rotor ignition; the R/T 70 cc cylinder requires the following two additional ignition adjustments:

Ignition point BTDC*	Cable grounded (green)	Characteristics
3,2mm	Yes	Flat curve, lower exhaust gas temperature
3,6mm	No	Steep curve, higher exhaust gas temperature

\*before top dead centre

## 6. Dimensional Stability

In order to ensure consistent quality standards, all cylinders are subject to quality checks. During these checks, cylinders are measured and reworked under computer control. As it is not possible to work without any tolerances, it is decided after production how deep the inner cylinder head cap will have to be inserted. According to our experience, this is the best way to ensure that cylinders can be provided within the same port timing area. The number engraved on the inner cap represents the insertion depth (e.g. /02 = 2.2 mm, /03 = 2.3 mm, /04 = 2.4 mm).

Over the years, both we and our customers have placed increasing demands on engine components. This is one of the major reasons why

in this area no expense and effort has been spared to develop a cylinder that sets new standards for power and quality. Still one shouldn't forget that these engine parts are made to bring home victories, not simply to look good.

At this point we'd also like to mention that microscopic shrinkage cavities may occasionally occur below the front transfer ports. However, these cavities do not impair function, longevity or power in any way.

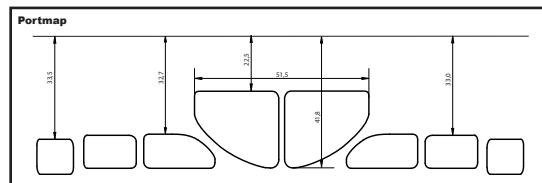

## 7. Component Overview

Cylinder kit	Exhaust	Crankshaft	Ignition
Stage6 R/T 70 MK I, Minarelli LC	Stage6 R/T 70	Stage6 R/T	Stage6 R/T Replica
S6-7516602	S6-9616605	S6-7916685/12	S6-7916688/12
			S6-4516600

Carburettor	Reed valve	Intakte manifold
S6-30DEL-19 S6-30DEL-21	S6-3219066/VT	S6-3316602/VT
S6-31RT-PWK21 S6-31RT-PWK24 S6-30RT-VHST24/K	S6-3219066/VT	S6-3316617/OR
S6-31RT-PWK26 S6-31RT-PWK28 S6-30RT-VHST28/K	S6-3219066/VT	S6-3316617/OR

### 8. Replacement Parts

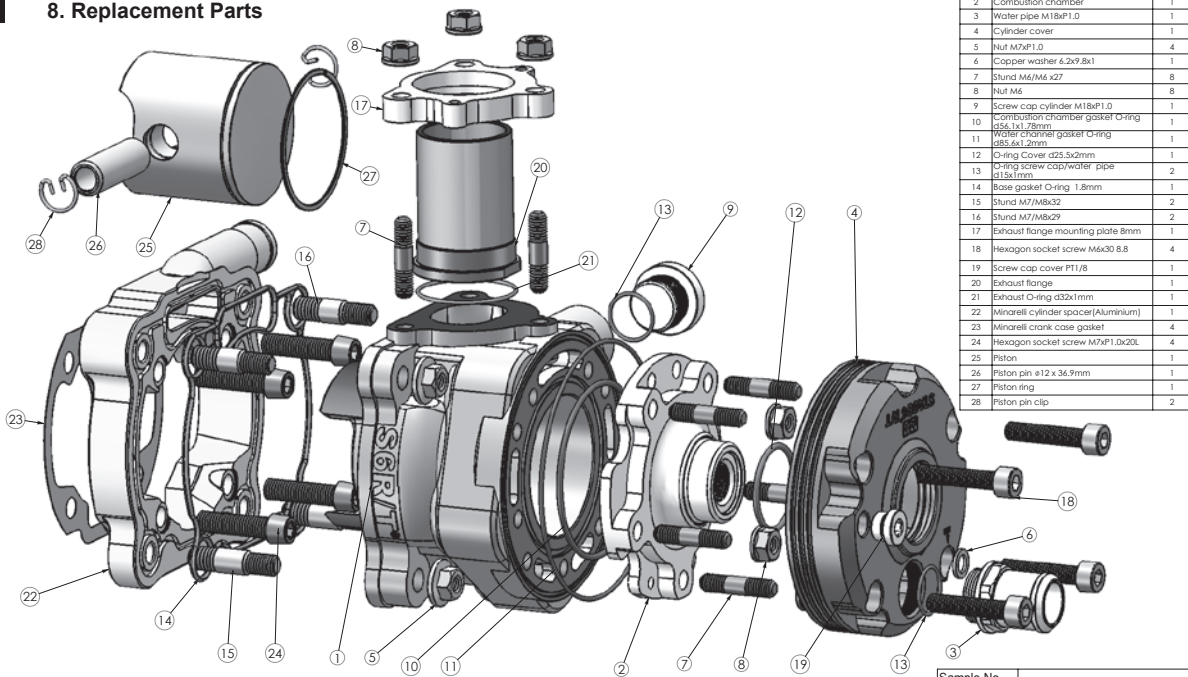

Item	Description	Quantity
1	HIGH END 70cc Cylinder	1
2	Combustion chamber	1
3	Water pipe M18xP1.0	1
4	Cylinder cover	1
5	Nut M7xP1.0	4
6	Copper washer 6.2x9.8x1	1
7	Stud M6/M6 x27	8
8	Nut M6	8
9	Screw cap cylinder M18xP1.0	1
10	connection chamber gasket o-ring d35.1x1.78mm	1
11	Water channel gasket O-ring d35.6x1.2mm	1
12	O-ring Cover d25.5x2mm	1
13	O-ring screw cap/water pipe d19x1mm	2
14	Base gasket O-ring 1.8mm	1
15	Stud M7/M8x32	2
16	Stud M7/M8x29	2
17	Exhaust flange mounting plate 8mm	1
18	Hexagon socket screw M6x30 8.8	4
19	Screw cap cover P11/8	1
20	Exhaust flange	1
21	Exhaust O-ring d32x1mm	1
22	Minarelli cylinder spacer(Aluminium)	1
23	Minarelli crank case gasket	4
24	Hexagon socket screw M7xP1.0x20L	4
25	Piston	1
26	Piston pin ø12 x 36.9mm	1
27	Piston ring	1
28	Piston pin clip	2

Sample No.

Model	R/T 70 Minarelli	Drawn	Koopmans/Koch	SIZE	A3	Title	explosion drawing	Version	A
Material	CHKD		FK 2009.06.09	Scale	1:1	Item No.			
Surface treatment	APPVD			Unit	MM				
Note				Sheet	1 of 1				



### Component (see picture) Description

Component (see picture)	Description	Part no.
-	<b>Cylinder Kit Stage6 R/T 70 MK I, Minarelli LC</b>	<b>S6-7516602</b>
20	Exhaust flange set Stage6 R/T 70, for Stage6 R1400, Minarelli	S6-75166EK52
20	Exhaust flange set Stage6 R/T 70, for Malossi MHR TEAM, Minarelli	S6-75166EK54
20	Exhaust flange set Stage6 R/T 70, for Yasuni C20/C21/C30, Minarelli	S6-75166EK56
22	Cylinder adaptor plate incl. studs Stage6 R/T 70, Minarelli LC – aluminium	S6-75166ET02
22	Cylinder adaptor plate incl. studs Stage6 R/T 70, Minarelli LC – steel	S6-75166ET03
23	Base gasket Stage6 R/T 70, copper (0.8 mm), Minarelli LC	S6-75166ET05
23	Base gasket Stage6 R/T 70, aluminium (1.0 mm), Minarelli LC	S6-75166ET06
23	Gasket set (alloy) Stage6 R/T 70/85/95 – Minarelli LC	S6-75166ET20
24	Screw set for cylinder adaptor plate Stage6 R/T 70, Minarelli LC (4 pcs.)	S6-75166ET34
20	Exhaust flange set Stage6 R/T 70, universal, do-it-yourself	S6-75EK50
20	Exhaust flange set Stage6 R/T 70, for Stage6 R/T 70, Piaggio/Minarelli	S6-75EK51
1	Cylinder Stage6 R/T 70 MK I	S6-75ET01
2	Inner cylinder head cap Stage6 R/T 70, MK I (2.2 mm)	S6-75ET02/02
2	Inner cylinder head cap Stage6 R/T 70, MK I (2.3 mm)	S6-75ET02/03
2	Inner cylinder head cap Stage6 R/T 70, MK I (2.4 mm)	S6-75ET02/04
2	Inner cylinder head cap Stage6 R/T 70, MK I (2.5 mm)	S6-75ET02/05
2	Inner cylinder head cap Stage6 R/T 70, MK I (2.6 mm)	S6-75ET02/06
2	Inner cylinder head cap Stage6 R/T 70, unmachined (4 mm)	S6-75ET02/40U
4 + 3	Cylinder head cover incl. water connection Stage6 R/T 70/85/95	S6-75ET10
9	Screw plug for water passage Stage6 R/T 70/85/95	S6-75ET12
3	Water connection Stage6 R/T 70/85/95	S6-75ET13
7 + 8 + 18	Screw set for cylinder kit Stage6 R/T 70/85/95	S6-75ET15
6 + 10 + 11 + 12 + 13 + 14 + 21	Seal set (O-rings) Stage6 R/T 70/85/95	S6-75ET22
17	Exhaust flange mounting plate Stage6 R/T 70	S6-75ET23
21	O-ring set exhaust Stage6 R/T 70, (5 pcs.)	S6-75ET25
15 + 16	Stud set for cylinder adaptor plate Stage6 R/T 70/85/95	S6-75ET27
26	Gudgeon pin Stage6 R/T 70, 12 x 37 mm	S6-75KB20
25 + 26 + 27 + 28	Piston set Stage6 R/T 70 (A), 12 mm gudgeon pin	S6-75KO10.A
25 + 26 + 27 + 28	Piston set Stage6 R/T 70 (B), 12 mm gudgeon pin	S6-75KO10.B
25 + 26 + 27 + 28	Piston set Stage6 R/T 70 (C), 12 mm gudgeon pin	S6-75KO10.C
25 + 26 + 27 + 28	Piston set Stage6 R/T 70 (D), 12 mm gudgeon pin	S6-75KO10.D
27	Piston ring Stage6 R/T 70, 47.6 x 1 mm	S6-75KR01
28	Gudgeon pin circlip Stage6, 12 mm	S6-KC12
-	Sealing compound Stage6 silicone, 70 ml	S6-0100



EN

Configuration Notes

---

---

---

---

---

---

---

---

---

---

Configuration Notes

---

---

---

---

---

---

---

---

---

---